

## High Current 180 Ampere Pi Suppressor Integrated Filtering and Impulse Suppression

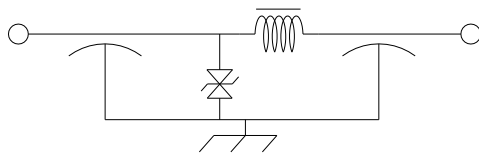

Circuit Schematic

- ✓ Excellent EMI filtering
- ✓ Transient Suppression
- ✓ Compact and lightweight
- ✓ "Pi" Type Filter
- ✓ Bolt-Style Electrode Attachment
- ✓ High Shock & Vibration
- ✓ CDR and JAN Reliability levels available

### Voltage & Capacitance

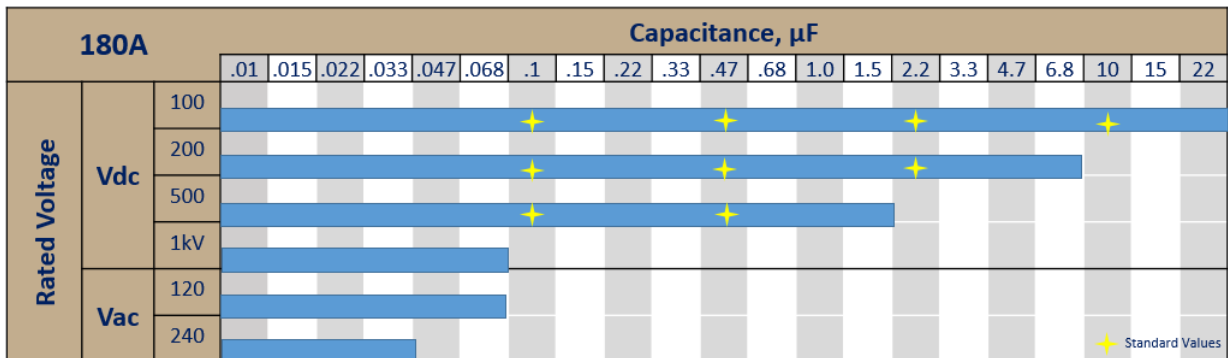

### Insertion Loss

Actual Insertion Loss Performance Varies According to Configuration. See Performance Curve to the right for possible configurations.

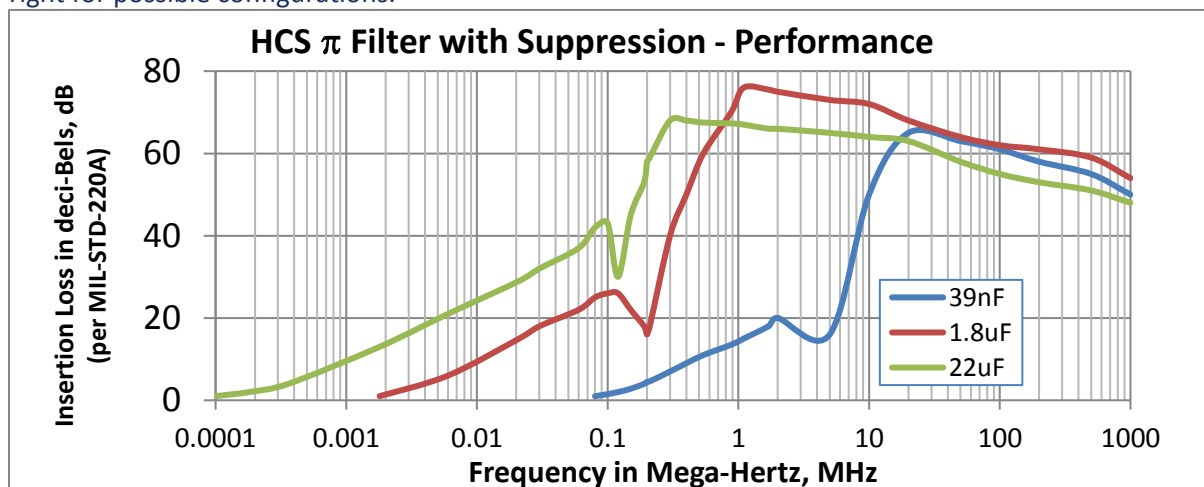

## Impulse Suppression Configurations and Performance

NOTE: DC voltage is asymmetrical, opposite polarity is 5 volt rated.

Standard Suppression Code	Nominal Voltage	Breakdown		Transient Current Rating (8x20µs)			
		Minimum Vdc	Current in mA	Standard		Maximum	
				Apeak	Vpeak	Apeak	Vpeak
2A	240Vac	+/-497V	5	300	798	1000	837
1A	120Vac	+/-257V	5	600	413	2000	433
05	-48Vdc	-73/+10	5	1800	-122	3500	-125
04	+48Vdc	+73/-10	5	1800	122	3500	125
02	28Vdc	+39/-8	5	2500	81	3500	82
01	12Vdc	+19/-8	50	3500	29		

The HCS products contain internal zener suppressors to reduce transient voltage pulses. The circuit is normally oriented with the zeners stage in parallel with the capacitors on the bulkhead end.

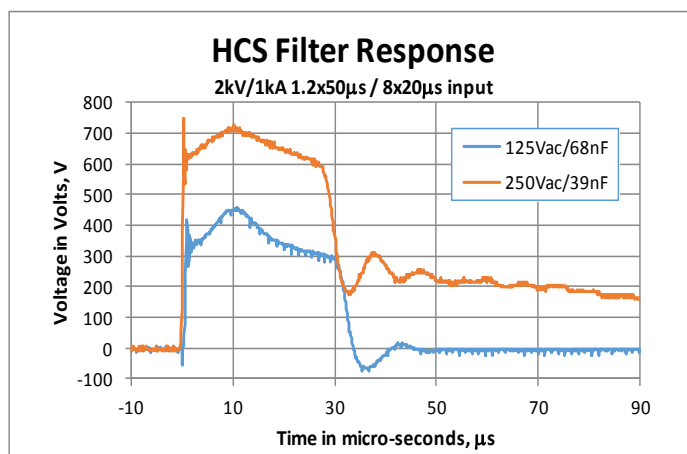
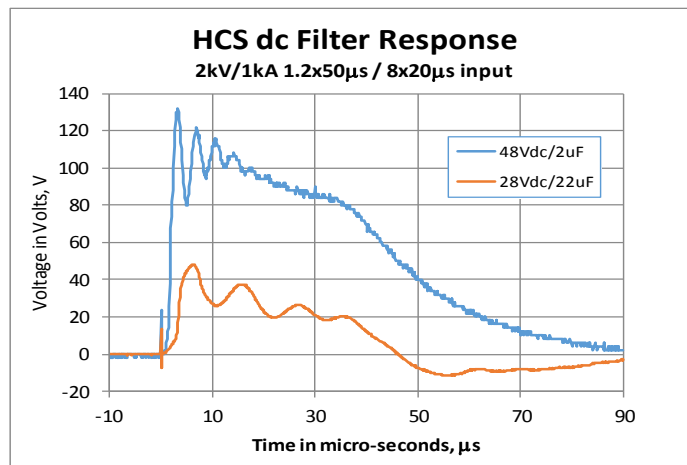

## Specifications

(Units to MIL-C-49467, MIL-C-55681, MIL-C-123 or customer SCD available in E-Series)

Parameter	Value	Description / Specification / Method
Current	180 Amperes	
Insertion Loss	See Performance Curve on page	Per Capacitor Value
RF Current	10A <sub>rms</sub>	
Insulation	100ΩF (100MΩ Maximum) at	MIL-STD-202 Method 302
Nominal Voltage	+12,+ 24-28, + or -48Vdc, 120 or	
Maximum Voltage	125% of nominal dc or ac peak	
Transient Current	1kA to 3kA (8x20μs pulse)	0.1% maximum duty cycle
Transient Response	170% of Nominal Voltage	
Dissipation Factor	3% Maximum	MIL-STD-202 Method 306
Voltage Drop	20mVdc - 24mV(60Hz)	Wire to Wire
Operating Temp	-55°C to +125°C	18A@125°C to 180A@90°C
Temperature Rise	30°C Typical at 180A (at sea level)	
Heat Rise Constant	4.4 to 8.0	C <sub>1</sub> in formula ΔT=C <sub>1</sub> x W <sup>0.85</sup>
Storage	-55°C to +105°C	
Fungus	Non-Nutrient	MIL-HDBK-454A
Corrosion (metal)	5% NaCl / 35°C / 48 hrs	MIL-STD-202 Method 101D / Cond B
Sealing	IP67	IEC-529
Humidity	98%RH 25°C-65°C	MIL-STD-202 Method 106E
Shock	30g – 11ms	MIL-STD-202 Method 213B / Cond A
Terminal Strength	Torque: 72 in-lbs (8 N·m) Pull: 200lbs (90kg)	MIL-STD-202 Method 211A / Cond A & E
Reliability(MTBF)	500,000 hrs	MIL-HDBK-217F Cond - N2 A(IF) 70°C

## Mechanical Specifications

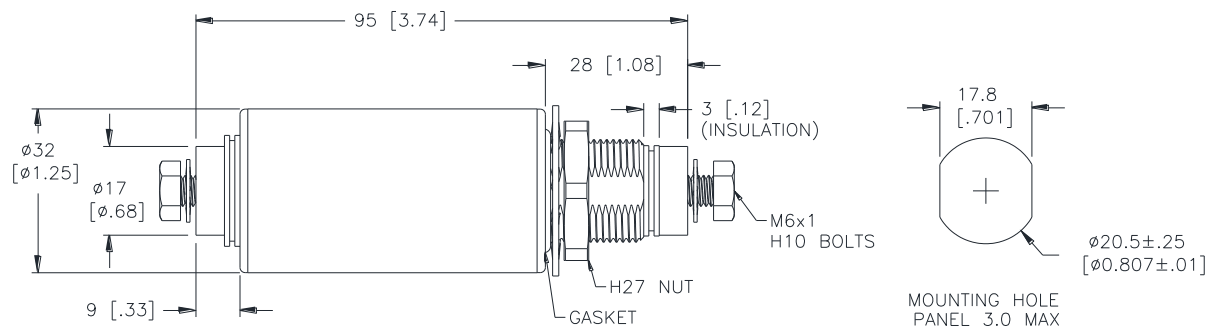

## Materials

Component	Material	Finish
Body and Mounting Nut	Aluminum	Electroless Nickel
Bolts and hardware	Stainless Steel	Passivated
Electrode	Copper Alloy	Tin
Insulator	CPVC	none

## Mounting



**Installation Torque Recommendations**  
 Electrode Lug Nut Torque: 72 in-lbs (8 N·m)  
 Mounting Panel Nut Torque: 350 in-lbs (40 N·m)

**INSTALLATION NOTE:**  
 Always place current-carrying wire lug or busbar directly against the flat electrode face of the HCP180. Do not use any hardware (lockwashers, extra nuts, etc.) between the current-carrying conductor and this flat electrode face.

## Part Number

Device	Current	Capacitance	Tolerance	Suppression	Series
HCP	180	XXXX	X	XX	X

- Device** HCS High Current Pi Suppressor
- Current** Current rating in amperes
- Capacitance** in picofarads, first two digits are significant, last two digits are number of zeros  
e.g. 2203 = 22,000pF / 4704 = .47μF
- Tolerance** Capacitor Code: Z= +80%/-20% (Standard), M= +/-20%, K= +/-10%
- Suppression** 01=+12V, 03=+24/+28V, 04=+48V, 05=-48V, 1A=120Vac, 2A=240Vac
- Series** Optional series designator
- Example** HCP1801004Z10 = Feedthrough Pi Filter / 180A / 0.10uF / +80%/-20% / 100Vdc

## Safety Tips

- ✓ The filter should be mounted in a grounded shielding panel
- ✓ Tighten the electrode nuts to the torque specified
- ✓ Cover exposed electrode nuts
- ✓ Observe temperature, current, & voltage limits
- ✓ Always install lug or busbar directly against center boss/flat